



The Pennsylvania System of School Assessment

Science Item and Scoring Sampler



2007–2008
Grade 8

TABLE OF CONTENTS

Introduction	1
General Scoring Guidelines for Science	2
Science Reporting Categories	3
Description of Sample Items	3
Description of Science Scenarios.	3
Multiple-Choice Items	4
First Open-Ended Item.	10
Item-Specific Scoring Guideline	11
Open-Ended Item Responses	12
Second Open-Ended Item	15
Item-Specific Scoring Guideline	16
Open-Ended Item Responses	17
Third Open-Ended Item	20
Item-Specific Scoring Guideline	21
Open-Ended Item Responses	22
Science Scenario	25

SCIENCE

INTRODUCTION

General Introduction

The Department of Education provides districts and schools with tools to assist in delivering focused instructional programs aligned to the state assessment system. These tools include assessment anchor documents, assessment handbooks, and content-based item and scoring samplers. This 2007–2008 Science Item and Scoring Sampler is a useful tool for Pennsylvania educators in the preparation of local instructional programs and the statewide Pennsylvania System of School Assessment (PSSA).

What Is Included

This item and scoring sampler contains a science scenario as well as science multiple-choice and open-ended items. These items provide an idea of the types of items that will appear on the operational Spring 2008 PSSA. Each item has been through a rigorous review process to ensure alignment with the Assessment Anchors.

Purpose and Uses

The items in this sampler may be used as examples for creating assessment items at the classroom level, and they may also be copied and used as part of a local instructional program.* Classroom teachers may find it beneficial to have students respond to the open-ended items in the sampler. Educators can then use the sampler as a guide to score the responses either independently or together with colleagues within a school or district.

Item Format and Scoring Guidelines

The multiple-choice items have four answer choices. Each correct response to a multiple-choice item is worth one point.

Each short open-ended (SOE) item is designed to take about ten minutes to complete. During an actual testing event, students are given additional time as necessary to complete the test items. The SOE items in science are scored with item-specific scoring guidelines on a 0–2 scale. An item-specific scoring guide is presented within this sampler and is similar to those that will be used to score open-ended items in future science PSSAs.

Also included is the General Scoring Guidelines for Science used to develop the item-specific guidelines. The General Scoring Guidelines for Science should be used to develop any item-specific scoring guidelines created for use within local instructional programs.*

The science scenario presents a topic or common theme that is explored by four multiple-choice items.

* The permission to copy and/or use these materials does not extend to commercial purposes.

SCIENCE

GENERAL SCORING GUIDELINES FOR SCIENCE

2 – The response demonstrates a *thorough* understanding of the scientific content, concepts, and procedures required by the task(s).

The response provides a clear, complete, and correct response as required by the task(s).
The response may contain a minor blemish or omission in work or explanation that does not detract from demonstrating a *thorough* understanding.

1 – The response demonstrates a *partial* understanding of the scientific content, concepts, and procedures required by the task(s).

The response is somewhat correct with *partial* understanding of the required scientific content, concepts, and/or procedures demonstrated and/or explained. The response may contain some work that is incomplete or unclear.

0 – The response provides *insufficient* evidence to demonstrate any understanding of the scientific content, concepts, and procedures as required by the task(s) for that grade level.

The response may show only information copied or rephrased from the question or *insufficient* correct information to receive a score of 1.

Special categories within zero reported separately:

BLK (blank) – No response or written refusal to respond or too brief to determine response

OT – Off task/topic

LOE – Response in a language other than English

IL – Illegible

SCIENCE

SCIENCE REPORTING CATEGORIES

Science scores are reported in four categories:

- A – The Nature of Science
- B – Biological Sciences
- C – Physical Sciences
- D – Earth and Space Sciences

DESCRIPTION OF SAMPLE ITEMS

The science stand-alone multiple-choice items begin on page 4. Each item is preceded by the Assessment Anchor and Eligible Content coding. Answer options A–D are followed by a brief analysis or rationale of each option. The correct multiple-choice answer is indicated by an asterisk (*) in the item and labeled as “Key” in the analysis.

Stand-alone 2-point SOE items follow the multiple-choice items. Each SOE item includes an item-specific scoring guide and samples of responses with scores and annotations.

One science scenario follows the stand-alone items; it is composed of scenario text and graphics and four multiple-choice items.

DESCRIPTION OF SCIENCE SCENARIOS

Included in this sampler are multiple-choice questions associated with a science scenario. Scenarios utilize content-rich stimuli and are specifically aligned to the Pennsylvania educator-developed Eligible Content. The science scenario may cover several pages and may contain text, graphics, charts, and/or tables, and may use these elements to describe the results of a class project, an experiment, or other similar research. Science scenarios address connections between multidisciplinary and interdisciplinary content domains (e.g., creating stronger connections between The Nature of Science and other science content).

When answering the items associated with scenario stimuli, students are required to use their content knowledge and science process skills. That is, some of the scenario items require that students use content knowledge to answer content-based questions, and other scenario items require that students process pertinent information from the scenario to answer questions.

SCIENCE

MULTIPLE-CHOICE ITEMS

A.2.1.5

Use the table below to answer question 1.

Laundry Detergent Comparison

Type of Stain	Number of Washes to Remove Stain		
	Detergent X	Detergent Y	Detergent Z
mud	1	1	1
ink	2	3	3
ketchup	1	2	2
grass	1	2	2

1. Students tested three different types of laundry detergent to determine how effective they were at removing stains. The washing was done with the same washing machine set at the same water temperature. Each type of stain was on the same fabric and was the same size and shape. The students recorded the number of times the fabric had to be washed to completely remove each stain. The students had a null hypothesis: Detergents X, Y, and Z are equally effective at removing stains. Which conclusion is **best** supported by the data?
- A Detergent X is more effective than both Y and Z at removing these stains. *
 - B Detergent Y is more effective than both X and Z at removing these stains.
 - C Detergent X is more effective than Y at removing stains, but equal in effectiveness to Z.
 - D Detergent Z is more effective than X at removing stains, but equal in effectiveness to Y.

- A *Key: Detergent X is the most effective detergent because it removed the ink, ketchup, and grass stains in the fewest number of washes and removed mud as well as detergents Y or Z.*
- B *Detergent Y is less effective than detergent X.*
- C *Detergent X is more effective than detergent Z.*
- D *Detergent Z is less effective than detergent X.*

SCIENCE

A.3.3.1

Use the drawing below to answer question 2.

Truss Bridge

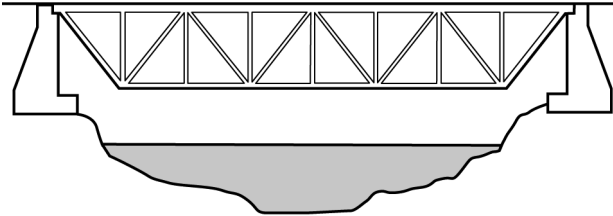

2. Which geometric shape is the most basic recurring element in the truss bridge?

- A cube
- B square
- C trapezoid
- D triangle *

- A Cubes are not a recurring element in the actual construction of the bridge.
- B The squares are actually composed of triangles; thus, the triangle is the basic unit.
- C Although the overall outline appears trapezoidal, the triangle is the basic unit of the bridge.
- D Key: The triangle is the basic unit of the bridge.

A.2.1.2

3. Students have observed a flock of birds near the school. They want to do an investigation that involves the birds. Which question is a testable question?

- A Do these birds migrate south every winter?
- B Why are the birds near the school?
- C Do the birds like to eat only at one feeder?
- D How many birds come to a feeder with sunflower seeds? *

- A *This is not a testable question in this setting.*
- B *This is not a testable question.*
- C *This is not a testable question.*
- D *Key: This is a testable question. Students can set up a feeder with sunflower seeds and record the numbers of birds that are attracted to it.*

SCIENCE

A.1.3.2

Use the graph below to answer question 4.

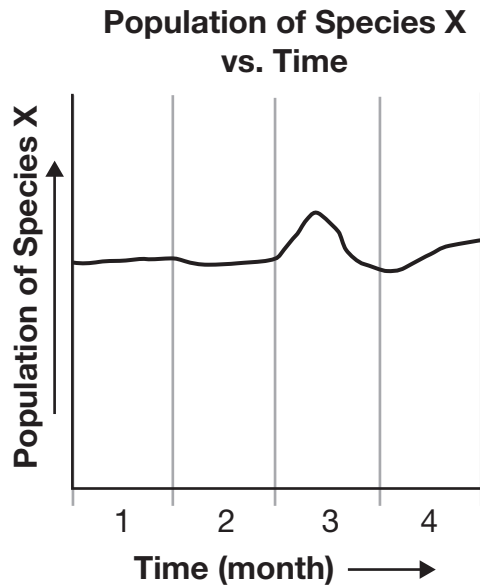

4. Which event explains what **most likely** happened at the beginning of month 3?
- A More predators of species X were introduced.
 - B The prey of species X decreased in number.
 - C A disease that affected species X was introduced.
 - D A competitor of species X decreased in number. *

- A *This would have decreased the number of X individuals.*
- B *This would have decreased the number of X individuals.*
- C *This would have decreased the number of X individuals.*
- D *Key: This allows species X individuals to take the food items shared with its competitor, thus increasing X's number.*

B.3.3.1

5. A small lake has an algae bloom, and the water is very green. Which change is **most likely** the cause of the algae growth?
- A an increase in the amount of fertilizer used near the lake *
 - B an increase in the amount of fresh water flowing into the lake
 - C an increase in the number of people fishing in the lake
 - D an increase in the number of boats using the lake

- A *Key: Fertilizer runoff that increased nutrients in the lake is the likely cause.*
- B *Increased amounts of fresh water added to the lake would dilute nutrient levels.*
- C *Too many people fishing is not likely to cause an algae bloom.*
- D *Boats are not likely to put nutrients into the lake.*

SCIENCE

A.3.1.2

Use the table below to answer question 6.

Organisms and Their Energy Sources

Organism	Energy Source
fungus	breaks down dead organisms
mouse	eats seeds, fruits, nuts
oak tree	conducts photosynthesis
lynx	eats other animals

6. In which trophic pyramid are the organisms correctly displayed?

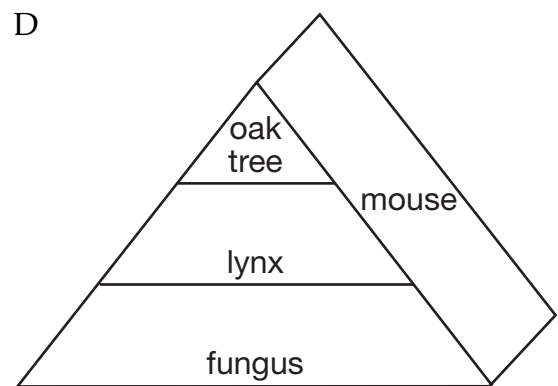
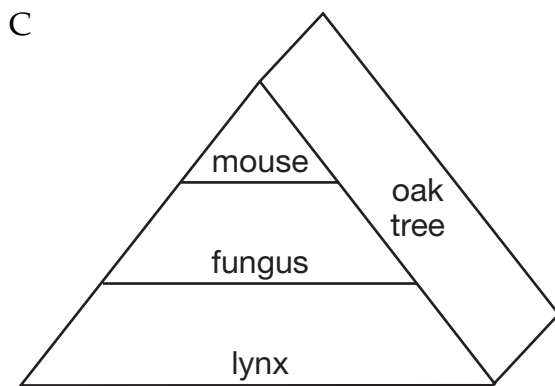
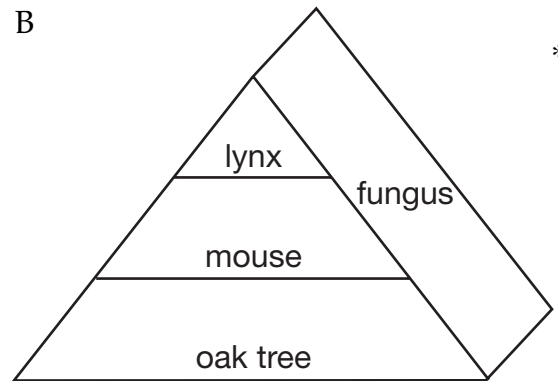
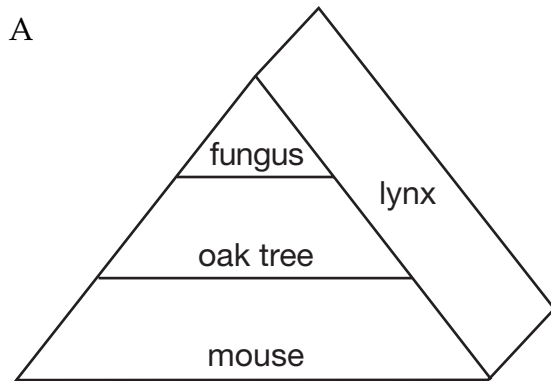

- A The oak tree is the producer and should be displayed at the base of the trophic pyramid.
- B Key: The organisms in this pyramid are correctly displayed by trophic level.
- C The oak tree's energy source is the Sun and not the other organisms.
- D The mouse is a primary consumer and does not get its energy from the lynx or fungus.

SCIENCE

C.2.2.3

7. Which statement correctly describes an energy source and its effect on the environment?
- A Fossil fuel, which comes from a continuously renewable resource, generates greenhouse gases.
 - B Solar power, which comes from a continuously renewable resource, generates greenhouse gases.
 - C Nuclear energy, which comes from a nonrenewable resource, generates dangerous waste. *
 - D Hydroelectric power, which comes from a nonrenewable resource, generates dangerous waste.

- A *Fossil fuel is derived from a nonrenewable resource. The burning of fossil fuel generates greenhouse gases.*
- B *Solar power typically does not generate greenhouse gases.*
- C *Key: Nuclear energy is derived from a nonrenewable resource; nuclear power plants generate low- and high-level radioactive waste products (solid, liquid, and gas).*
- D *Hydroelectric power is derived from a renewable resource; it does not typically generate dangerous waste.*

D.1.3.1

8. Which statement correctly describes a water cycle process?
- A Evaporation can occur when water gains energy from the Sun and changes into water vapor. *
 - B Condensation can occur when liquid water molecules in clouds lose energy and fall to Earth.
 - C Transpiration can occur when atmospheric water vapor gains energy and moves higher in the atmosphere.
 - D Precipitation can occur when atmospheric water vapor loses energy and forms liquid water droplets.

- A *Key: This is a correct description of the process of evaporation.*
- B *Condensation occurs when water vapor turns into liquid water molecules.*
- C *Transpiration occurs when water evaporates from plants.*
- D *Precipitation occurs when water vapor condenses in the air and falls to Earth.*

SCIENCE

C.1.1.2

Use the table below to answer question 9.

Characteristics of Hematite and Galena

Hematite	Galena
gray color metallic-looking red streak 4.9 to 5.3 times more dense than water	gray color metallic-looking dark gray streak 7.4 to 7.6 times more dense than water

9. Two unknown metallic-looking minerals appear gray in color. They are of equal size, yet one is heavier than the other. One unknown mineral is hematite and the other is galena. According to the characteristics listed in the table, which explanation is correct for mineral samples of equal size?
- A Galena is the heavier mineral because it is less dense than hematite and weighs more.
 - B Galena is the heavier mineral because it is more dense than hematite and weighs more. *
 - C Hematite is the heavier mineral because it is less dense than galena and weighs more.
 - D Hematite is the heavier mineral because it is more dense than galena and weighs more.

- A *Galena is more dense than hematite.*
- B *Key: Density = mass/volume. If both minerals have the same volume, then the mineral with more mass is denser. The table shows that galena has a greater density.*
- C *Hematite does not weigh more than galena.*
- D *Hematite weighs less and is less dense than galena.*

SCIENCE

FIRST OPEN-ENDED ITEM

D.3.1.2

This is a short open-ended (SOE) question. It is worth two points.

Use the diagram and table below to answer question 10.

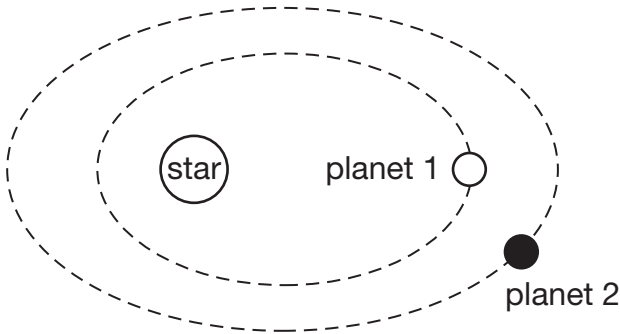

Mass Comparison

Object	Mass (kg)
planet 1	6.0×10^{24}
planet 2	6.5×10^{23}
star	2.0×10^{30}

10. Answer parts A and B below about the movements of the objects in this star system.

Part A: How is the movement of planet 1 in this star system influenced by the other two objects in this star system?

Star: _____

Planet 2: _____

Part B: Which part of this star system has the greatest influence on movement of objects within the star system? Explain your answer.

SCIENCE

ITEM-SPECIFIC SCORING GUIDELINE

Item #10

This item will be reported under Category D, Earth and Space Sciences.

Assessment Anchor:

D.3.1 Explain the relationships between and among the objects of our solar system.

Specific Eligible Content addressed by this item:

D.3.1.2 Describe the role of gravity as the force that governs the movement of the solar system and universe.

Scoring Guide:

Part A: How is the movement of planet 1 in this star system influenced by the other two objects in this star system?

Part B: Which part of this star system has the greatest influence on movement of objects within this star system? Explain your answer.

Score	In this item, the student—
2	demonstrates a <i>thorough</i> understanding of gravity and the relationships of planetary motion by clearly stating that planet 1's motion is influenced by gravitational pull from both the star and planet 2 and stating that the star has the greatest influence on objects within this system because its mass is greatest. The response is clear, complete, and correct.
1	demonstrates a <i>partial</i> understanding of gravity and the relationships of planetary motion by clearly stating that planet 1's motion is influenced by gravitational pull from both the star and planet 2 or stating that the star has the greatest influence on objects within this system because its mass is greatest. The response may contain some work that is incomplete or unclear.
0	provides <i>insufficient</i> evidence to demonstrate any understanding of the content being tested.
Non-scorable	BLK (blank) – No response or written refusal to respond or response too brief to determine response OT – Off task/topic LOE – Response in a language other than English IL – Illegible

Note: No deductions should be taken for misspelled words or grammatical errors.

SCIENCE

OPEN-ENDED ITEM RESPONSES

Response Score: 2

D.3.1.2

This is a short open-ended (SOE) question. It is worth two points.

Use the diagram and table below to answer question 10.

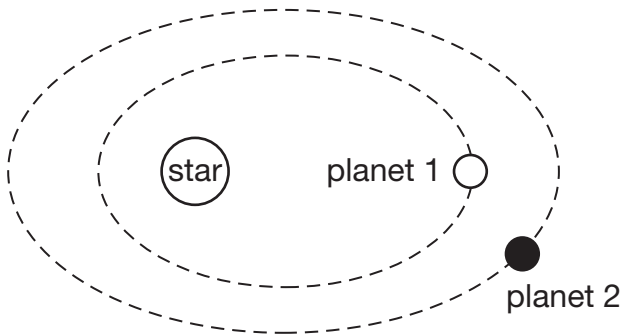

Mass Comparison

Object	Mass (kg)
planet 1	6.0×10^{24}
planet 2	6.5×10^{23}
star	2.0×10^{30}

10. Answer parts A and B below about the movements of the objects in this star system.

Part A: How is the movement of planet 1 in this star system influenced by the other two objects in this star system?

Star: has gravitational pull on Planet 1.

Planet 2: has gravitational pull on Planet 1.

The student response to part A is correct.

Part B: Which part of this star system has the greatest influence on movement of objects within the star system? Explain your answer.

The Star because it has the most mass in the star system.

The student response to part B is correct.

SCIENCE

Response Score: 1

D.3.1.2

This is a short open-ended (SOE) question. It is worth two points.

Use the diagram and table below to answer question 10.

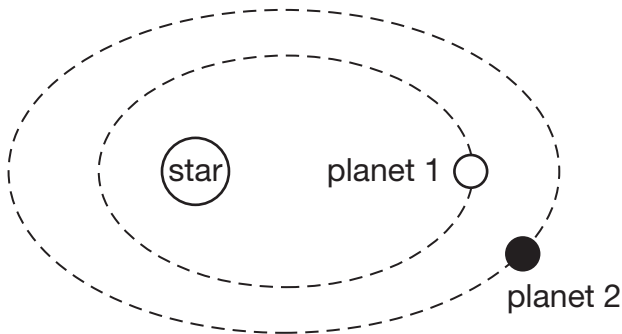

Mass Comparison

Object	Mass (kg)
planet 1	6.0×10^{24}
planet 2	6.5×10^{23}
star	2.0×10^{30}

10. Answer parts A and B below about the movements of the objects in this star system.

Part A: How is the movement of planet 1 in this star system influenced by the other two objects in this star system?

Star: Gravitational pull from the star influences
the movement of Planet 1.

Planet 2: Gravitational pull from Planet 2 influences
the movement of Planet 1.

The student response to part A is correct.

Part B: Which part of this star system has the greatest influence on movement of objects within the star system? Explain your answer.

The star because it is very hot and bright.

The student response to part B is incorrect. The star's temperature and brightness do not influence the movement of planet 1 or planet 2.

SCIENCE

Response Score: 0

D.3.1.2

This is a short open-ended (SOE) question. It is worth two points.

Use the diagram and table below to answer question 10.

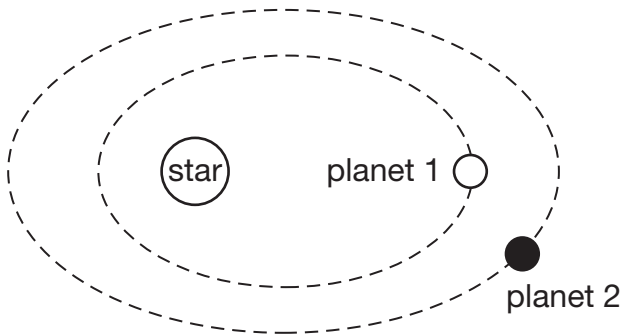

Mass Comparison

Object	Mass (kg)
planet 1	6.0×10^{24}
planet 2	6.5×10^{23}
star	2.0×10^{30}

10. Answer parts A and B below about the movements of the objects in this star system.

Part A: How is the movement of planet 1 in this star system influenced by the other two objects in this star system?

Star: Planet 1 and Planet 2 revolve around the Star.

Planet 2: _____

The student response to part A is incorrect. General information about the revolutions of both planets does not answer the question.

Part B: Which part of this star system has the greatest influence on movement of objects within the star system? Explain your answer.

The Star because it sends out solar flares that causes both planets to move.

The student response to part B is incorrect. Solar flares do not impact the movements of planets in a star system.

SCIENCE

SECOND OPEN-ENDED ITEM

B.3.3.1

This is a short open-ended (SOE) question. It is worth two points.

11. The Arctic National Wildlife Refuge in Alaska is over 19 million acres of land. Its unique habitat supports at least 45 species of land and marine animals, 36 species of fish, and 180 species of birds. Some people want to drill for oil in parts of the refuge. Scientists estimate that the total amount of recoverable oil in the refuge is between 5 and 16 billion barrels.

Part A: Describe an environmental problem that could be caused by drilling for oil in Alaska.

Part B: Describe a regional benefit of drilling for oil in Alaska.

SCIENCE

ITEM-SPECIFIC SCORING GUIDELINE

Item #11

This item will be reported under Category B, Biological Sciences.

Assessment Anchor:

- B.3.3 Explain how renewable and nonrenewable resources provide for human needs or how these needs impact the environment.

Specific Eligible Content addressed by this item:

- B.3.3.1 Explain how human activities may affect local, regional, and global environments.

Scoring Guide:

Part A: Describe an environmental problem that could be caused by drilling for oil in Alaska.

Part B: Describe a regional benefit of drilling for oil in Alaska.

Score	In this item, the student—
2	demonstrates a <i>thorough</i> understanding of the impact that drilling for oil in Alaska will have on the environment by describing an environmental problem that could be caused by drilling, and describing a regional benefit drilling in Alaska could provide to the region. The response is clear, complete, and correct.
1	demonstrates a <i>partial</i> understanding of the impact that drilling for oil in Alaska will have on the environment by describing an environmental problem that could be caused by drilling, or describing a regional benefit drilling in Alaska could provide to the region. The response may contain some work that is incomplete or unclear.
0	provides <i>insufficient</i> evidence to demonstrate any understanding of the content being tested.
Non-scorable	BLK (blank) – No response or written refusal to respond or response too brief to determine response OT – Off task/topic LOE – Response in a language other than English IL – Illegible

Note: No deductions should be taken for misspelled words or grammatical errors.

SCIENCE

OPEN-ENDED ITEM RESPONSES

Response Score: 2

B.3.3.1

This is a short open-ended (SOE) question. It is worth two points.

11. The Arctic National Wildlife Refuge in Alaska is over 19 million acres of land. Its unique habitat supports at least 45 species of land and marine animals, 36 species of fish, and 180 species of birds. Some people want to drill for oil in parts of the refuge. Scientists estimate that the total amount of recoverable oil in the refuge is between 5 and 16 billion barrels.

Part A: Describe an environmental problem that could be caused by drilling for oil in Alaska.

If oil is spilled, it can kill plants and animals for a long time.

The student response to part A is correct.

Part B: Describe a regional benefit of drilling for oil in Alaska.

Drilling for oil will create jobs and help people make money.

The student response to part B is correct.

SCIENCE

Response Score: 1

B.3.3.1

This is a short open-ended (SOE) question. It is worth two points.

11. The Arctic National Wildlife Refuge in Alaska is over 19 million acres of land. Its unique habitat supports at least 45 species of land and marine animals, 36 species of fish, and 180 species of birds. Some people want to drill for oil in parts of the refuge. Scientists estimate that the total amount of recoverable oil in the refuge is between 5 and 16 billion barrels.

Part A: Describe an environmental problem that could be caused by drilling for oil in Alaska.

Dil can pollute the environment and hurt many animals.

The student response to part A is correct.

Part B: Describe a regional benefit of drilling for oil in Alaska.

Drilling for oil will stop earthquakes from happening.

The student response to part B is incorrect. Drilling for oil does not control or stop earthquakes from occurring.

SCIENCE

Response Score: 0

B.3.3.1

This is a short open-ended (SOE) question. It is worth two points.

11. The Arctic National Wildlife Refuge in Alaska is over 19 million acres of land. Its unique habitat supports at least 45 species of land and marine animals, 36 species of fish, and 180 species of birds. Some people want to drill for oil in parts of the refuge. Scientists estimate that the total amount of recoverable oil in the refuge is between 5 and 16 billion barrels.

Part A: Describe an environmental problem that could be caused by drilling for oil in Alaska.

Oil is expensive and we should
drive cars less.

The student response to part A is incorrect. The cost of oil and driving cars less often are not environmental problems caused by drilling for oil.

Part B: Describe a regional benefit of drilling for oil in Alaska.

Drilling for oil it will help
animals migrate.

The student response to part B is incorrect. Drilling for oil does not benefit animal migration.

SCIENCE

THIRD OPEN-ENDED ITEM

A.2.2.3

This is a short open-ended (SOE) question. It is worth two points.

12. Answer parts A and B below about how a doctor uses microscopes.

Part A: Describe one way microscopes are used to help doctors determine whether people are healthy.

Part B: Describe one way a doctor's job would be different if the doctor did **not** have a microscope as a tool for diagnosis.

SCIENCE

ITEM-SPECIFIC SCORING GUIDELINE

Item #12

This item will be reported under Category A, The Nature of Science.

Assessment Anchor:

- A.2.2 Apply appropriate instruments for a specific purpose and describe the information the instrument can provide.

Specific Eligible Content addressed by this item:

- A.2.2.3 Describe ways technology extends and enhances human abilities for specific purposes (e.g., microscope, telescope, micrometer, hydraulics, barometer).

Scoring Guide:

Part A: Describe one way microscopes are used to help doctors determine whether people are healthy.

Part B: Describe one way a doctor's job would be different if the doctor did **not** have the microscope as a tool for diagnosis.

Score	In this item, the student—
2	demonstrates a <i>thorough</i> understanding of how technology extends human abilities by describing how microscopes are used and explaining how a doctor's job would be different without microscopes. The response is clear, complete, and correct.
1	demonstrates a <i>partial</i> understanding of how technology extends human abilities by providing a complete answer to one part of the question or a very general answer to both of the parts. The response may contain some work that is incomplete or unclear.
0	provides <i>insufficient</i> evidence to demonstrate any understanding of the content being tested.
Non-scorable	BLK (blank) – No response or written refusal to respond or response too brief to determine response OT – Off task/topic LOE – Response in a language other than English IL – Illegible

Note: No deductions should be taken for misspelled words or grammatical errors.

SCIENCE

OPEN-ENDED ITEM RESPONSES

Response Score: 2

A.2.2.3

This is a short open-ended (SOE) question. It is worth two points.

12. Answer parts A and B below about how a doctor uses microscopes.

Part A: Describe one way microscopes are used to help doctors determine whether people are healthy.

The doctor can look for small things like bacteria.

The student response to part A is correct.

Part B: Describe one way a doctor's job would be different if the doctor did **not** have a microscope as a tool for diagnosis.

The doctor might need to conduct more tests to help a person get better.

The student response to part B is correct.

SCIENCE

Response Score: 1

A.2.2.3

This is a short open-ended (SOE) question. It is worth two points.

12. Answer parts A and B below.

Part A: Describe one way microscopes are used to help doctors determine whether people are healthy.

Cells can be examined closely by a doctor.

The student response to part A is correct.

Part B: Describe one way a doctor's job would be different if the doctor did **not** have the microscope as a tool for diagnosis.

The doctor could better study more diseases.

The student response to part B is incorrect. The lack of a microscope would limit the ability of the doctor to study diseases.

SCIENCE

Response Score: 0

A.2.2.3

This is a short open-ended (SOE) question. It is worth two points.

12. Answer parts A and B below about how a doctor uses microscopes.

Part A: Describe one way microscopes are used to help doctors determine whether people are healthy.

Microscopes can take a person's
body temperature.

The student response to part A is incorrect. A microscope is not a tool that can help measure a person's body temperature.

Part B: Describe one way a doctor's job would be different if the doctor did **not** have a microscope as a tool for diagnosis.

The doctor would have more
time to treat people.

The student response to part B is incorrect. The reference to the doctor's availability to treat people does not answer the question.

SCIENCE SCENARIO

Directions: Use the information presented on pages 25 and 26 to answer questions 13 through 16.

Students made the device shown in the experimental setup below for testing the effects of different electromagnetic fields on substances. The testing device has three batteries, three coils of insulated copper wire, one iron rod, three adjustable selector switches, and one on/off switch with a power indicator light.

Experimental Setup

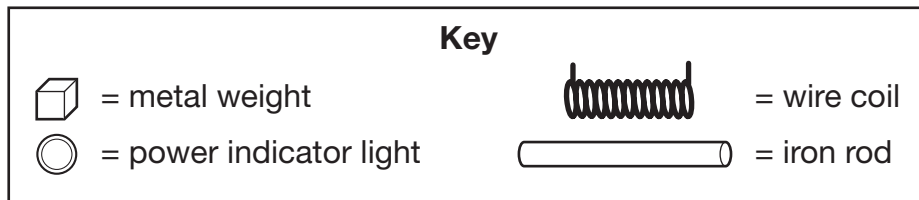
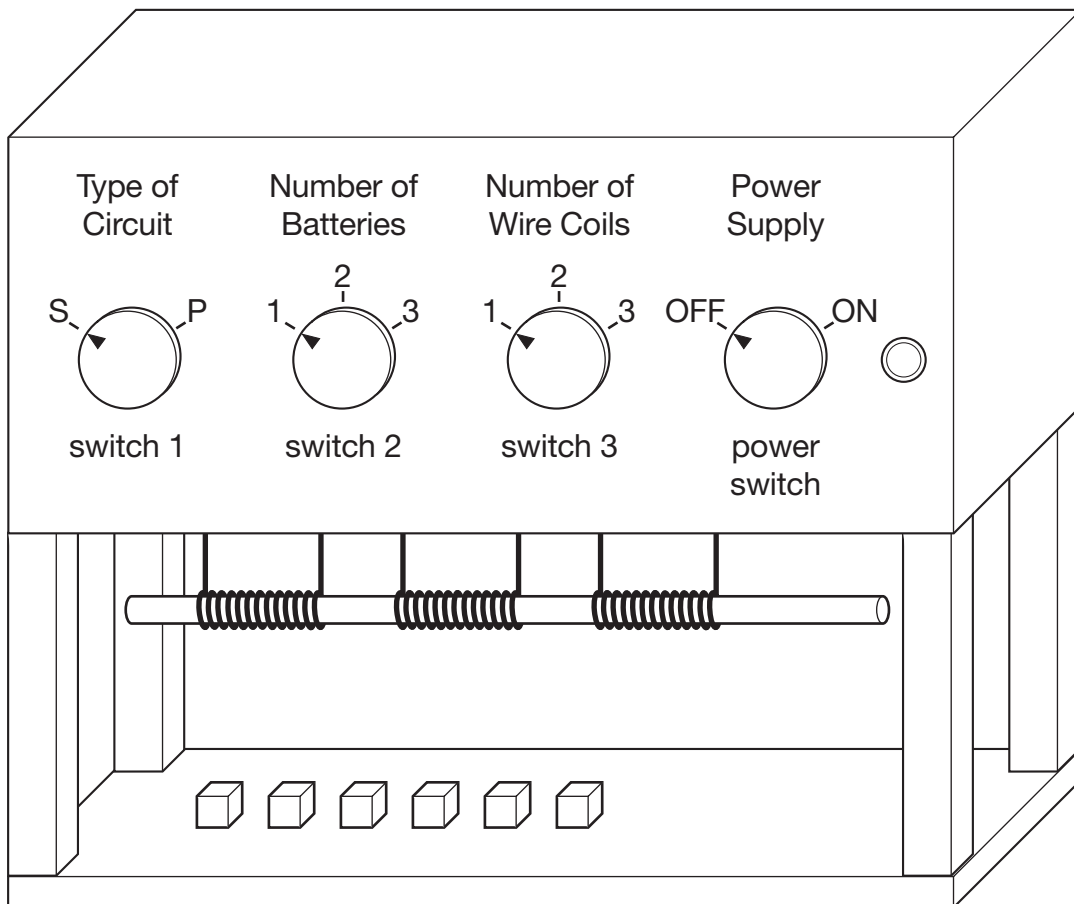

SCIENCE SCENARIO

Directions: Use the information presented on pages 25 and 26 to answer questions 13 through 16.

Six metal weights are available for the tests; each weight has the same volume and mass. The strength of the electromagnet is measured by counting the number of metal weights that can be suspended from the rod like a chain. A description of the functions of the device's switches is below.

Functions of Adjustable Selector Switches

- switch 1: determines whether the batteries are part of a series circuit (S) or a parallel circuit (P)
- switch 2: determines the number of batteries that are part of the circuit
- switch 3: determines the number of wire coils that are receiving electrical current

SCIENCE SCENARIO

Directions: Use the information presented on pages 25 and 26 to answer questions 13 through 16.

C.2.1.3

13. Which sequence correctly shows the energy conversions that allow the testing device to attract a metal weight with magnetic properties?
- A battery (chemical to heat) → wire coil (heat to magnetic) → metal weight (magnetic to frictional)
 - B battery (chemical to electrical) → wire coil (electrical to magnetic) → metal weight (magnetic to mechanical) *
 - C battery (electrical to magnetic) → wire coil (magnetic to heat) → metal weight (heat to mechanical)
 - D battery (electrical to mechanical) → wire coil (mechanical to magnetic) → metal weight (magnetic to gravitational)

- A *Heat is not a useful form of energy in this sequence, so it does not play a role in this setup.*
- B *Key: Chemical energy from the battery is converted into electrical energy, which moves through the wire; the electrical energy is converted to magnetic energy in the electromagnet, which in turn, pulls and holds the cube to the rod.*
- C *Heat is not a useful form of energy in this sequence, so it does not play a role in this setup.*
- D *There is no direct transformation from electrical energy to mechanical energy in this setup.*

SCIENCE SCENARIO

Directions: Use the information presented on pages 25 and 26 to answer questions 13 through 16.

A.2.1.6

14. Students attempted to use the device and the weights in an investigation. None of the metal weights were attracted to the electromagnet when they were placed near it. The students made sure that the power indicator light was on, then they tried every switch combination. Which system modification and test are necessary to solve the design flaw in the experimental setup?
- A Use copper metal weights and test the batteries.
 - B Use a copper rod and test the batteries.
 - C Use smaller metal weights and test the original weights and the smaller weights with a bar magnet. *
 - D Use a larger iron rod and test the original metal weights with a bar magnet.

- A *Copper is not magnetic.*
- B *Copper is not magnetic.*
- C *Key: Testing with a bar magnet will determine whether the cubes are magnetic. Smaller cubes would verify whether the original metal weights were too massive.*
- D *A larger iron rod will not help to determine whether there is a flaw in the system.*

C.3.1.1

15. Which statement correctly describes the forces acting on the metal weights when the system design prevented them from being attracted to the electromagnet?
- A The balanced magnetic and gravitational forces were insufficient to overcome the inertia of the metal weight. *
 - B The balanced frictional and gravitational forces were insufficient to overcome the momentum of the metal weight.
 - C The unbalanced frictional and gravitational forces were insufficient to overcome the inertia of the metal weight.
 - D The unbalanced magnetic and gravitational forces were insufficient to overcome the momentum of the metal weight.

- A *Key: For an object to move, an unbalanced force must act on it.*
- B *A frictional force that does not have a significant role in this device.*
- C *If the forces acting on the cube were unbalanced, the cube would move.*
- D *If the forces acting on the cube were unbalanced, the cube would move.*

SCIENCE SCENARIO

Directions: Use the information presented on pages 25 and 26 to answer questions 13 through 16.

A.2.1.3

16. The power switch is on. Which procedure will **best** determine the type of circuit that makes an electromagnet?
- A Set switch 1 to S.
Change switches 2 and 3 to every combination.
Observe the motion of the metal weights.
 - B Set switch 1 to P.
Change switches 2 and 3 to every combination.
Observe the motion of the metal weights.
 - C Set switch 2 to a constant setting.
Change switches 1 and 3 to every combination.
Observe the motion of the metal weights.
 - D Set switches 2 and 3 to constant settings.
Change switch 1 from P to S.
Observe the motion of the metal weights. *

- A *This procedure would not test both types of circuits.*
- B *This procedure would not test both types of circuits.*
- C *This procedure tests too many variables.*
- D *Key: This procedure tests the type of circuits while holding other variables constant.*

**Science
Grade 8
Item and Scoring Sampler**

Copyright © 2007 by the Pennsylvania Department of Education. The materials contained in this publication may be duplicated by Pennsylvania educators for local classroom use. This permission does not extend to the duplication of materials for commercial use.