

OPEN-ENDED QUESTIONS

Use the diagram below to answer question 17.

Mars Exploration Rover Landing System

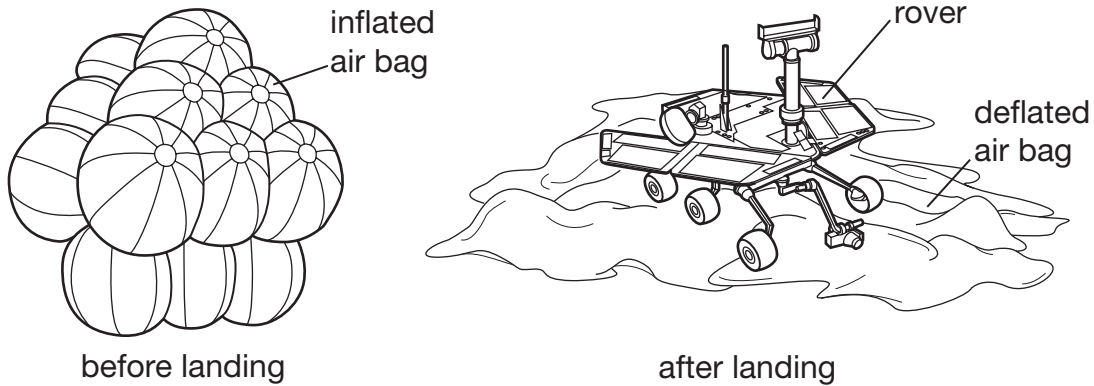

17. The landing system for the Mars Exploration Rover spacecraft used a system of air bags to protect its fragile rover during landing. Engineers first used a computer simulation to test the new air bag design; then they used crash tests with various types of vehicles.

Part A: Describe one benefit of using a computer simulation to test the air bag design before conducting crash tests.

Part B: Explain how crash tests help engineers test the air bag design.

Albert Einstein



WBTE Preview

Question 18



Describe two ways that animals respond to the seasonal weather changes in Pennsylvania.

1.

0 / 1000

Ed

2.

0 / 1000

Ed

0 / 1000

Back

Options

Flag

Pause

Review/End Test

OPEN-ENDED ITEM

Use the food web below to answer question 17.

The title is Food Web. The labels on the food web from bottom to top, and left to right are: plants, rabbit, deer, and wolf. There is an upward pointing arrow from plants to rabbit and from plants to deer. There is an upward pointing arrow from rabbit to wolf, and from deer to wolf.

17. A student drew a basic food web of a forest ecosystem.

Part A. Describe what the arrows represent in the food web.

Part B. Explain why the ecosystem supports fewer wolves than deer.

OPEN-ENDED ITEM

18. Antibiotics and vaccinations are used by many people around the world to treat and prevent illnesses.

Describe a possible positive effect and a possible negative effect of the widespread use of antibiotics or vaccinations.

Positive Effect:

Negative Effect:

OPEN-ENDED ITEM

17. Meteor Crater is a rimmed, bowl-shaped feature that lies in the desert of northern Arizona. The crater measures 1,200 meters (m) in diameter, with the crater floor lying 180 m beneath the rim. The rim rises about 60 m above the surrounding desert. In the early twentieth century, most scientists theorized that the crater formed as a result of volcanic activity (volcanism theory). However, Daniel Barringer proposed that a powerful meteor impact formed the crater (impact theory).

Part A: Explain why the impact theory is classified as a theory rather than an opinion.

Part B: Barringer’s impact theory was eventually accepted by a majority of scientists. Describe what is needed for a new theory to become widely accepted by the scientific community.

AFTER YOU HAVE CHECKED YOUR WORK, CLOSE YOUR ANSWER BOOKLET AND TEST BOOKLET SO YOUR TEACHER WILL KNOW YOU ARE FINISHED.



OPEN-ENDED ITEM

18. Use the drawing below to answer the question.

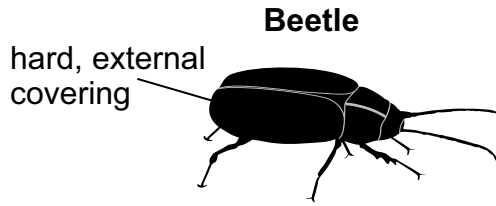

Beetles have a hard, external covering on their bodies.

Part A: Describe one function of the hard, external covering on the beetle.

Part B: Identify a human body structure and describe how its function is similar to the hard, external covering of a beetle.

Human Body Structure: _____

Similarity in Function: _____

AFTER YOU HAVE CHECKED YOUR WORK, CLOSE YOUR ANSWER BOOKLET AND TEST BOOKLET SO YOUR TEACHER WILL KNOW YOU ARE FINISHED.

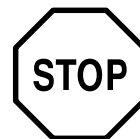

OPEN-ENDED ITEM

17. Use the information below to answer the question.

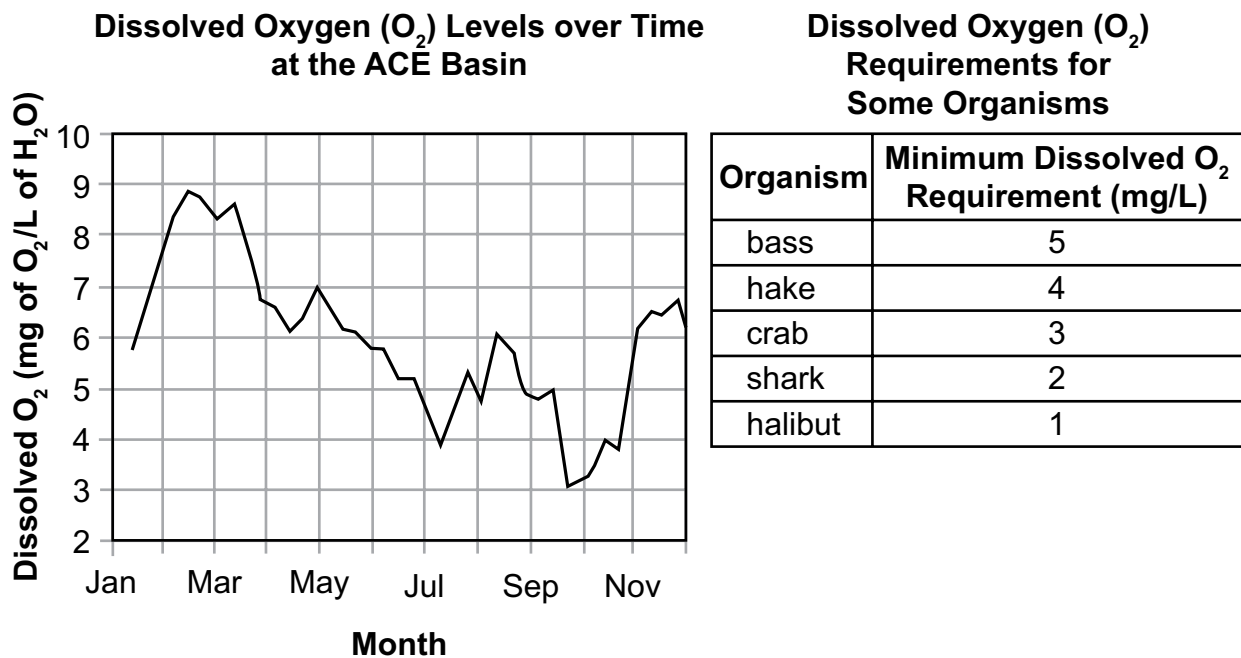

Scientists measured dissolved oxygen levels at the Ashepoo, Combahee, and Edisto (ACE) Basin National Estuarine Research Reserve.

Part A: Based on the data shown in the graph and the data table, predict which organism(s) would likely survive year-round in the ACE Basin.

Part B: Describe a possible reason for the changes in dissolved oxygen levels observed in the ACE Basin throughout the year.

AFTER YOU HAVE CHECKED YOUR WORK, CLOSE YOUR ANSWER BOOKLET AND TEST BOOKLET SO YOUR TEACHER WILL KNOW YOU ARE FINISHED.



OPEN-ENDED ITEM

18. Use the diagram below to answer the question.

Movement of the Indian Continental Plate

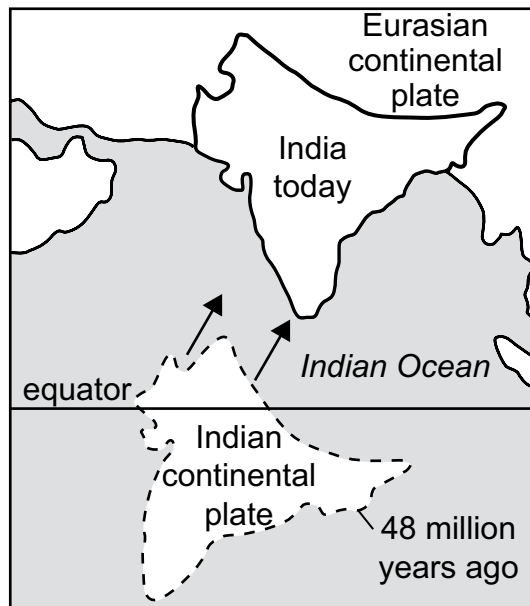

The diagram illustrates the movement of the Indian continental plate and its eventual collision with the Eurasian continental plate.

Part A: Describe the natural process that moved the Indian continental plate from its location 48 million years ago to its current location.

Part B: Describe the results of the collision between the Indian continental plate and the Eurasian continental plate.

AFTER YOU HAVE CHECKED YOUR WORK, CLOSE YOUR ANSWER BOOKLET AND TEST BOOKLET SO YOUR TEACHER WILL KNOW YOU ARE FINISHED.



SCIENCE

FIRST OPEN-ENDED ITEM

D.3.1.2

This is a short open-ended (SOE) question. It is worth two points.

Use the diagram and table below to answer question 10.

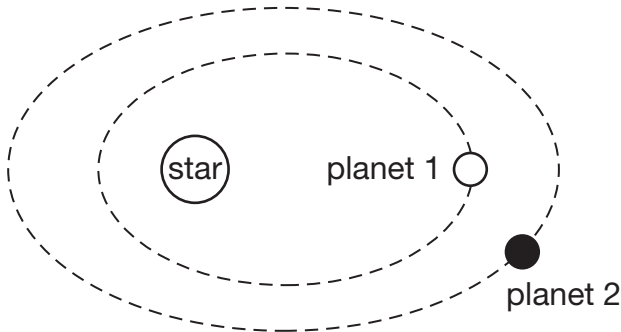

Mass Comparison

Object	Mass (kg)
planet 1	6.0×10^{24}
planet 2	6.5×10^{23}
star	2.0×10^{30}

10. Answer parts A and B below about the movements of the objects in this star system.

Part A: How is the movement of planet 1 in this star system influenced by the other two objects in this star system?

Star: _____

Planet 2: _____

Part B: Which part of this star system has the greatest influence on movement of objects within the star system? Explain your answer.

SCIENCE

SECOND OPEN-ENDED ITEM

B.3.3.1

This is a short open-ended (SOE) question. It is worth two points.

11. The Arctic National Wildlife Refuge in Alaska is over 19 million acres of land. Its unique habitat supports at least 45 species of land and marine animals, 36 species of fish, and 180 species of birds. Some people want to drill for oil in parts of the refuge. Scientists estimate that the total amount of recoverable oil in the refuge is between 5 and 16 billion barrels.

Part A: Describe an environmental problem that could be caused by drilling for oil in Alaska.

Part B: Describe a regional benefit of drilling for oil in Alaska.

SCIENCE

THIRD OPEN-ENDED ITEM

A.2.2.3

This is a short open-ended (SOE) question. It is worth two points.

12. Answer parts A and B below about how a doctor uses microscopes.

Part A: Describe one way microscopes are used to help doctors determine whether people are healthy.

Part B: Describe one way a doctor's job would be different if the doctor did **not** have a microscope as a tool for diagnosis.

SCIENCE SCENARIO

Directions: Use the information presented on pages 25 and 26 to answer questions 13 through 16.

Students made the device shown in the experimental setup below for testing the effects of different electromagnetic fields on substances. The testing device has three batteries, three coils of insulated copper wire, one iron rod, three adjustable selector switches, and one on/off switch with a power indicator light.

Experimental Setup

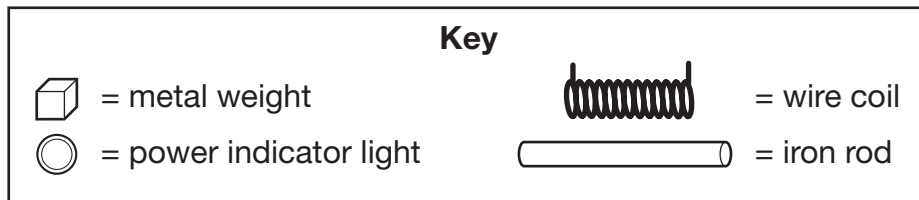
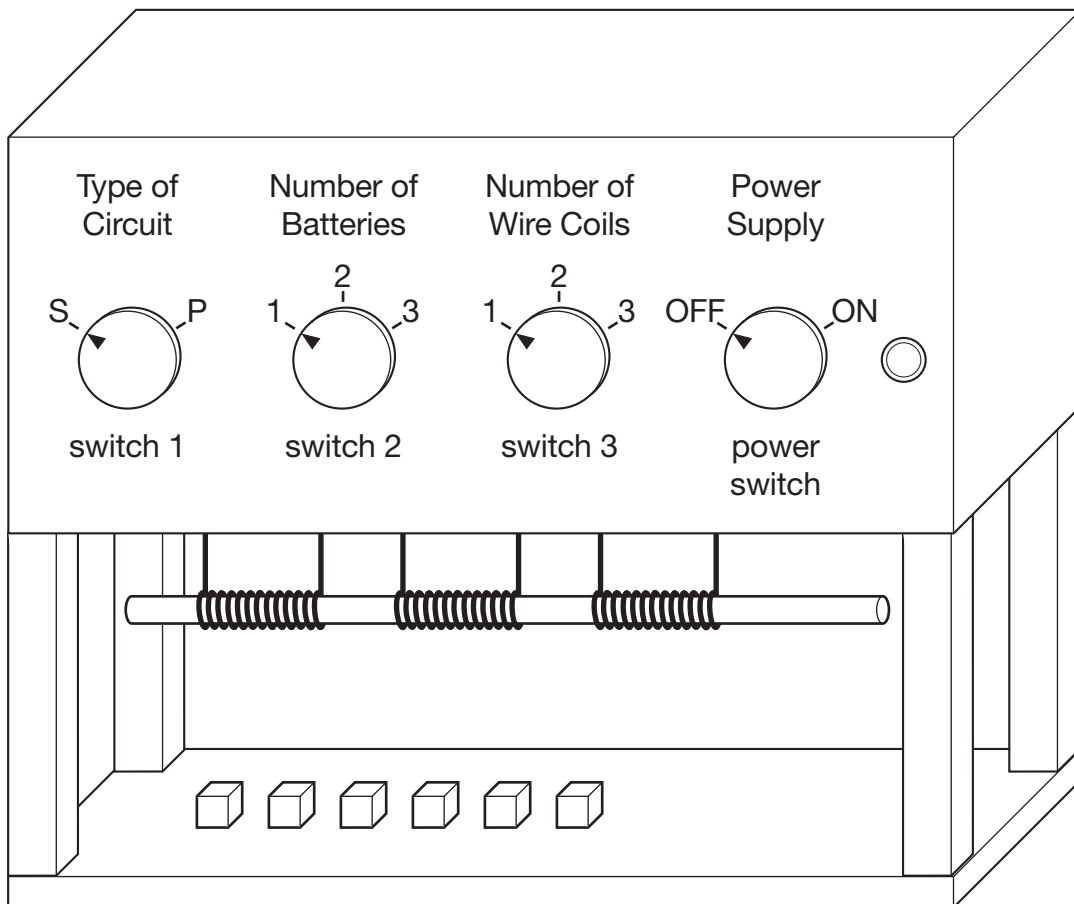

SCIENCE SCENARIO

Directions: Use the information presented on pages 25 and 26 to answer questions 13 through 16.

Six metal weights are available for the tests; each weight has the same volume and mass. The strength of the electromagnet is measured by counting the number of metal weights that can be suspended from the rod like a chain. A description of the functions of the device's switches is below.

Functions of Adjustable Selector Switches

- switch 1: determines whether the batteries are part of a series circuit (S) or a parallel circuit (P)
- switch 2: determines the number of batteries that are part of the circuit
- switch 3: determines the number of wire coils that are receiving electrical current

SCIENCE SCENARIO

Directions: Use the information presented on pages 25 and 26 to answer questions 13 through 16.

C.2.1.3

13. Which sequence correctly shows the energy conversions that allow the testing device to attract a metal weight with magnetic properties?
- A battery (chemical to heat) → wire coil (heat to magnetic) → metal weight (magnetic to frictional)
 - B battery (chemical to electrical) → wire coil (electrical to magnetic) → metal weight (magnetic to mechanical) *
 - C battery (electrical to magnetic) → wire coil (magnetic to heat) → metal weight (heat to mechanical)
 - D battery (electrical to mechanical) → wire coil (mechanical to magnetic) → metal weight (magnetic to gravitational)

- A *Heat is not a useful form of energy in this sequence, so it does not play a role in this setup.*
- B *Key: Chemical energy from the battery is converted into electrical energy, which moves through the wire; the electrical energy is converted to magnetic energy in the electromagnet, which in turn, pulls and holds the cube to the rod.*
- C *Heat is not a useful form of energy in this sequence, so it does not play a role in this setup.*
- D *There is no direct transformation from electrical energy to mechanical energy in this setup.*

SCIENCE SCENARIO

Directions: Use the information presented on pages 25 and 26 to answer questions 13 through 16.

A.2.1.6

14. Students attempted to use the device and the weights in an investigation. None of the metal weights were attracted to the electromagnet when they were placed near it. The students made sure that the power indicator light was on, then they tried every switch combination. Which system modification and test are necessary to solve the design flaw in the experimental setup?
- A Use copper metal weights and test the batteries.
 - B Use a copper rod and test the batteries.
 - C Use smaller metal weights and test the original weights and the smaller weights with a bar magnet. *
 - D Use a larger iron rod and test the original metal weights with a bar magnet.

- A *Copper is not magnetic.*
- B *Copper is not magnetic.*
- C *Key: Testing with a bar magnet will determine whether the cubes are magnetic. Smaller cubes would verify whether the original metal weights were too massive.*
- D *A larger iron rod will not help to determine whether there is a flaw in the system.*

C.3.1.1

15. Which statement correctly describes the forces acting on the metal weights when the system design prevented them from being attracted to the electromagnet?
- A The balanced magnetic and gravitational forces were insufficient to overcome the inertia of the metal weight. *
 - B The balanced frictional and gravitational forces were insufficient to overcome the momentum of the metal weight.
 - C The unbalanced frictional and gravitational forces were insufficient to overcome the inertia of the metal weight.
 - D The unbalanced magnetic and gravitational forces were insufficient to overcome the momentum of the metal weight.

- A *Key: For an object to move, an unbalanced force must act on it.*
- B *A frictional force that does not have a significant role in this device.*
- C *If the forces acting on the cube were unbalanced, the cube would move.*
- D *If the forces acting on the cube were unbalanced, the cube would move.*

SCIENCE SCENARIO

Directions: Use the information presented on pages 25 and 26 to answer questions 13 through 16.

A.2.1.3

16. The power switch is on. Which procedure will **best** determine the type of circuit that makes an electromagnet?
- A Set switch 1 to S.
Change switches 2 and 3 to every combination.
Observe the motion of the metal weights.
 - B Set switch 1 to P.
Change switches 2 and 3 to every combination.
Observe the motion of the metal weights.
 - C Set switch 2 to a constant setting.
Change switches 1 and 3 to every combination.
Observe the motion of the metal weights.
 - D Set switches 2 and 3 to constant settings.
Change switch 1 from P to S.
Observe the motion of the metal weights. *

- A *This procedure would not test both types of circuits.*
- B *This procedure would not test both types of circuits.*
- C *This procedure tests too many variables.*
- D *Key: This procedure tests the type of circuits while holding other variables constant.*

SCIENCE

A.2.1.5, B.3.2.3

This is a Short Open-Ended (SOE) question. It is worth two points.

Use the table below to answer question 14.

Plant Flowering Experiment

Species	Plant	Number of Hours		Receives 15 Minutes of Light during Dark Period?	Produces Flowers?
		In Light	In Dark		
X	1	14	10	no	yes
	2	10	14	yes	yes
	3	10	14	no	no
Y	4	14	10	no	no
	5	14	10	yes	no
	6	10	14	no	yes

14. A gardener wanted two plant species in his house to flower at the same time. He read that light is one factor that can affect whether plants produce flowers. The gardener designed an experiment to determine the effect of light on his two plant species (X and Y). He placed three plants of each species in separate rooms. Each plant was exposed to periods of light and dark. Some plants received an additional 15 minutes of light at the same time during the dark period. The results of the gardener's experiment are shown in the table.

A. Identify the plant **species** that needs long nights to flower and the plant **species** that needs short nights to flower. Explain your answers.

SCIENCE

B. Explain why 15 minutes of light helped one of the plants to produce flowers.

SCIENCE

FIRST OPEN-ENDED ITEM

A.2.1.2

Use the figures below to answer question 17.

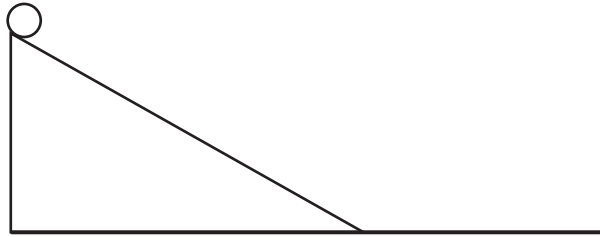
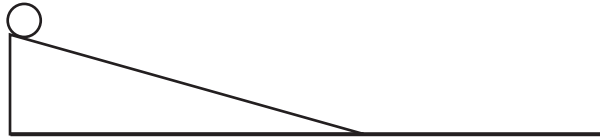

17. An experiment is set up to investigate how different ramps affect a ball's speed.

Part A: Create a question that could be tested using these two ramps.

Part B: State a hypothesis that could scientifically test the question.

Sampler Sequence	Scorepoint 2	Scorepoint 1	Scorepoint 0
17	50%	34%	16%

SCIENCE SCENARIO

MULTIPLE-CHOICE ITEMS

Directions: Use the information presented on pages 24 and 25 to answer questions 19 through 22.

A.2.2.3

19. When the student's parent heard about the cloud project, the parent gave the student a barometer and explained that it can help the student make weather predictions. How can this instrument help the student make weather predictions?

- A It measures pressure changes. *
- B It measures temperature changes.
- C It measures cloud precipitation.
- D It measures wind speed.

A *Key: Barometers are used to measure air pressure, and changes in air pressure generally indicate changes in the weather.*

B *Temperature changes are measured using thermometers.*

C *Precipitation is measured using rain gauges.*

D *Wind speed is measured using an anemometer.*

A	B	C	D
47%	14%	20%	20%

D.2.1.3

20. According to the student's observations, on which days would precipitation **most likely** have occurred?

- A Monday and Tuesday
- B Monday and Thursday
- C Wednesday and Thursday
- D Wednesday and Friday *

A *The clouds on Monday are cirrus clouds followed by light cumulus clouds on Tuesday. Neither of these is likely to cause precipitation.*

B *Both Monday and Thursday are clear days with some cirrus clouds, so rain is not likely.*

C *Slow rains seem likely for Wednesday, but the cirrus clouds on Thursday would not cause noticeable precipitation.*

D *Key: Wednesday is likely to have slow rains, while Friday is likely to have thunderstorms.*

A	B	C	D
6%	11%	9%	74%

SCIENCE SCENARIO

Directions: Use the information presented on pages 24 and 25 to answer questions 19 through 22.

D.1.3.1

21. Which physical process caused the clouds observed by the student to form from water vapor in the air?

- A condensation *
- B distillation
- C evaporation
- D sublimation

- A *Key: Water vapor is invisible. Condensation is required for droplets to form that make up clouds.*
- B *Distillation is a method used to separate mixtures of substances with different boiling points.*
- C *Evaporation forms water vapor, which is an invisible gas.*
- D *Sublimation is a process that causes a solid to change to a gaseous state without going through the liquid phase. If sublimation occurred within a cloud, it would become invisible water vapor.*

A	B	C	D
42%	7%	45%	6%

A.2.2.2

22. On a particular day, the student notices that the sky is filled with clouds of many different sizes. The student counts the number of big clouds, medium clouds, and little clouds, and records the number of each type. According to which quantity did the student organize the clouds?

- A elevation
- B water content
- C temperature
- D relative volume *

- A *In order to organize the clouds, by elevation, the elevation above the land would have to be measured.*
- B *The darkness of the clouds might indicate water content, but the darkness was not recorded.*
- C *The temperature of the clouds would have to be recorded with some type of aerial probe in order to group the clouds by temperature.*
- D *Key: Because the student recorded size, this is an indication of relative volume.*

A	B	C	D
18%	24%	8%	49%

OPEN-ENDED ITEM

Use the food web below to answer question 17.

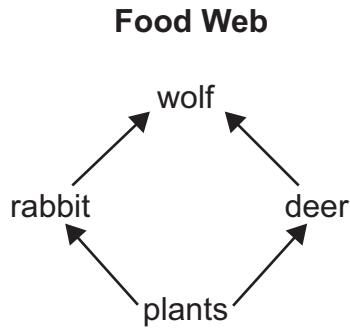

17. A student drew a basic food web of a forest ecosystem.

Part A: Describe what the arrows represent in the food web.

Part B: Explain why the ecosystem supports fewer wolves than deer.

OPEN-ENDED ITEM

18. Antibiotics and vaccinations are used by many people around the world to treat and prevent illnesses.

Describe a possible positive effect and a possible negative effect of the widespread use of antibiotics or vaccinations.

Positive Effect: _____

Negative Effect: _____
